

Астана +7(77172)727-132 Волгоград (844)278-03-48 Воронеж (473)204-51-73 Екатеринбург (343)384-55-89  
Казань (843)206-01-48 Краснодар (861)203-40-90 Красноярск (391)204-63-61 Москва (495)268-04-70  
Нижегород (831)429-08-12 Новосибирск (383)227-86-73 Ростов-на-Дону (863)308-18-15  
Самара (846)206-03-16 Санкт-Петербург (812)309-46-40 Саратов (845)249-38-78 Уфа (347)229-48-12  
Единый адрес: alg@nt-rt.ru Веб-сайт: aalborg.nt-rt.ru

Technical Data Sheet No. TD0305M Rev. C  
Date of Issue: May 2012

# OPERATING MANUAL

## SMV

### Stepping Motor Valve



Aalborg® reserves the right to make changes to information and specifications in this manual without notice.

# TABLE OF CONTENTS

<b>1.</b>	<b>UNPACKING THE SMV Motorized Valve.....</b>	<b>1</b>
1.1	Inspect Package for External Damage.....	1
1.2	Unpack the Motorized Valve.....	1
1.3	Returning Merchandise for Repair.....	1
<b>2.</b>	<b>INSTALLATION.....</b>	<b>2</b>
2.1	Primary Gas Connections.....	2
2.2	Electrical Connections.....	2
<b>3.</b>	<b>SPECIFICATIONS.....</b>	<b>4</b>
3.1	CE Compliance.....	5
<b>4.</b>	<b>OPERATING INSTRUCTIONS.....</b>	<b>6</b>
4.1	Preparation and Warm Up.....	6
4.2	Valve OFF Control (Open Collector NPN Compatible).....	7
4.3	Valve Purge/Open.....	7
<b>5.</b>	<b>TROUBLESHOOTING.....</b>	<b>8</b>
5.1	Common Conditions.....	8
5.2	Troubleshooting Guide.....	9
5.3	Technical Assistance.....	9

## **APPENDIX 1** DIMENSIONAL DRAWINGS

## **APPENDIX 2** WARRANTY

## TRADEMARKS

*Aalborg*<sup>®</sup> is a registered trademark of Aalborg Instruments.

*Buna*<sup>®</sup> is a registered trademark of DuPont Dow Elastomers.

*Kalrez*<sup>®</sup> is a registered trademark of DuPont Dow Elastomers.

*Viton*<sup>®</sup> is a registered trademark of Dupont Dow Elastomers L.L.C.

# **1. UNPACKING THE SMV MOTORIZED VALVE**

## **1.1 Inspect Package for External Damage**

Your **SMV Motorized Valve** was carefully packed in a sturdy cardboard carton, with anti-static cushioning materials to withstand shipping shock. Upon receipt, inspect the package for possible external damage. In case of external damage to the package contact the shipping company immediately.

## **1.2 Unpack the Motorized Valve**

Open the carton carefully from the top and inspect for any sign of concealed shipping damage. In addition to contacting the shipping carrier please forward a copy of any damage report to your distributor or Aalborg® directly.

When unpacking the instrument please make sure that you have all the items indicated on the Packing List. Please report any shortages promptly.

## **1.3 Returning Merchandise for Repair**

Please contact the customer service representative of your distributor or Aalborg® if you purchased your Motorized Valve directly, and request a **Return Authorization Number (RAN)**. **Equipment returned without an RAN will not be accepted.** Aalborg® reserves the right to charge a fee to the customer for equipment returned under warranty claims if the instruments are tested to be free from warrantied defects.

Shipping charges are borne by the customer. Items returned "collect" will not be accepted!

It is mandatory that any equipment returned for servicing be purged and neutralized of any dangerous contents including but not limited to toxic, bacterial-ly infectious, corrosive or radioactive substances. No work shall be performed on a returned product unless the customer submits a fully executed, signed SAFETY CERTIFICATE. Please request form from the Service Manager.

## **2. INSTALLATION**

### **2.1 Primary Gas Connections**

Prior to connecting gas lines inspect all parts of the piping system including ferrules and fittings for dust or other contaminants. Be sure to observe the direction of gas flow as indicated by the arrow on the front of the meter when connecting the gas system to be monitored.

Insert tubing into the compression fittings until the ends of the properly sized tubing home flush against the shoulders of the fittings. Compression fittings are to be tightened according to the manufacturer's instructions to one and one quarter turns. Avoid over tightening which will seriously damage fittings.

SMV Motorized Valves are supplied with standard 3/8 inch (SMV-20), 1/2 inch (SMV-30), or 3/4 inch (SMV-40) inlet and outlet compression fittings.

Using a Helium Leak Detector or other equivalent method perform a thorough leak test of the entire system. (All SMV's are checked prior to shipment for leakage within stated limits. See specifications in this manual.)

### **2.2 Electrical Connections**

The motorized valve requires a +12VDC power supply with a minimum current rating of 800 mA. Operating power and valve control signals are supplied via the 9-pin "D" connector located at the side of the valve. For normal operating the motorized valve requires at least two control signals:

- Direction (12V CMOS logic level, pin 8 on the 9-pin "D" connector)
- Speed (0-2.5 VDC analog signal, pin 4 on the 9-pin "D" connector)

When direction is LOW (GND) valve goes down (closes), when direction is HIGH valve goes up (opens). The "speed" voltage on pin 4 determines how quickly the valve will operate. The signal amplitude for "speed" control signal must remain within the limits of 0 to +2.5 VDC.

It may be necessary to override "direction" and "speed" signals with a preset (2.75 VDC) speed control signal. This can be accomplished with valve CLOSE and PURGE control signals (open collector NPN compatible). In order to CLOSE valve pin 3 on the 9-pin "D" connector has to be connected to GND (pin 2). A GREEN light on the top of the valve will indicate a CLOSE valve condition. In order to PURGE valve pin 7 on the 9-pin "D" connector has to be connected to GND (pin 2). A RED light on the top of the valve will indicate a fully OPEN valve condition.

During normal operation the valve remains in the last position as it is de-energized. After powering up, the valve will be automatically closed within the first 10 seconds and after that resumes control operation.

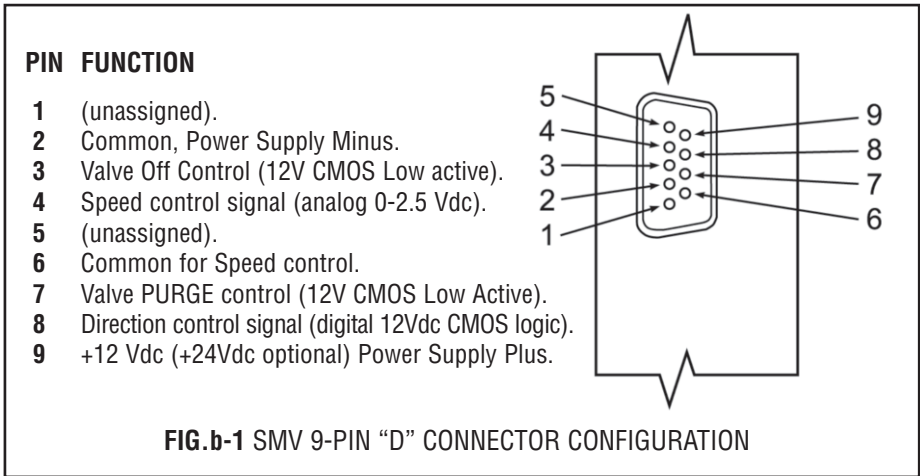

**WARNING:** DO NOT CONNECT 24 Vdc POWER SUPPLY UNLESS YOUR SMV VALVE WAS ORDERED AND CONFIGURED FOR 24Vdc VOLTAGE (SEE POWER REQUIREMENTS LABEL). DO NOT APPLY TO THE DIRECTION CONTROL SIGNAL (PIN 8) VOLTAGE MORE THAN 12 Vdc



**Important Notes:**

In general, "D" Connector numbering patterns are standardized. There are, however, some connectors with nonconforming patterns and the numbering sequence on your mating connector may or may not coincide with the numbering sequence shown in our pin configuration table above. It is imperative that you match the appropriate wires in accordance with the correct sequence regardless of the particular numbers displayed on your mating connector.

Make sure power is OFF when connecting or disconnecting any cables in the system.

The power input is protected by a 1600mA M (medium time-lag) resettable fuse. If a shorting condition or polarity reversal occurs, the fuse will cut power to the valve circuit. Disconnect the power to the unit, remove the faulty condition, and reconnect the power. The fuse will reset once the faulty condition has been removed.



Use of the SMV Motorized Valve in a manner other than that specified in this manual or in writing from Aalborg®, may impair the protection provided by the equipment.

### 3. SPECIFICATIONS

#### MATERIALS OF CONSTRUCTION:

**ALUMINUM MODELS:** Aluminum housings and valve blocks, Viton® O-Rings, PFA closing pins.

**STAINLESS/PTFE MODELS:** 316 stainless steel valve blocks, PTFE-lined Aluminum Housing blocks, Viton® O-Rings, and PFA closing pins.

**MAXIMUM FLOW RATES:** 1000 sL/min (air), 28 L/min (water).

**CONNECTIONS:** 3/8", 1/2", compression and 3/4" FNPT.

**ELECTRICAL CONNECTIONS:** 9-pin "D" connector, located at the side of the valve.

**POWER INPUT:** +12Vdc @ 800mA standard or optional +24Vdc @ 600mA. Power input is protected by 1600mA resettable fuse.

**DIRECTIONAL CONTROL SIGNAL:** 12Vdc CMOS compatible logic signal (10K input impedance). UP: Logic High (>7.5Vdc <= 12Vdc). Do not apply more than 12 Vdc. DOWN: Logic Low (<2.3Vdc).

**SPEED CONTROL SIGNAL:** Analog 0 to 2.5Vdc (100K input impedance).

**TTL ON/OFF OVERRIDE:** TTL low level to pins 7 and 3 (10K input impedance).

**RESPONSE TIME:** 100ms time constant.

**DIFFERENTIAL PRESSURES:** 700 to 1000 mbars (10 to 15 psid).

**MAXIMUM OPERATING PRESSURE:** 500 psig (35 bars).

**MAXIMUM DIFFERENTIAL PRESSURE:** 50 psig (3.45 bars).

**ENVIRONMENTAL (PER IEC 664):** Installation Level II; Pollution Degree II.

**GAS AND AMBIENT TEMPERATURE:** 32 °F to 122 °F (0 °C to 50 °C).

**LEAK INTEGRITY:**  $1 \times 10^{-7}$  sccs He max to the outside environment.

#### WETTED MATERIALS:

**SMV20/SMV30/SMV40:** Anodized aluminum, brass, and 316 stainless steel with VITON® O-rings seals; BUNA-N®, EPR or KALREZ® O-rings are optional.



**SMV20-S/SMV30-S/SMV40-S:** 316 stainless steel with VITON® O-rings seals; BUNA-N®, EPR or KALREZ® O-rings are optional.

Aalborg® makes no expressed or implied guarantees of corrosion resistance of Motorized Valves as pertains to different flow media reacting with components of valves. It is the customers' sole responsibility to select the model suitable for a particular gas based on the fluid contacting (wetted) materials offered in the different models.

### **3.1 CE Compliance**

Any model SMV bearing a CE marking on it, is in compliance with the below stated test standards currently accepted.

EMC Compliance with 89/336/EEC as amended;  
Emission Standard: EN 55011:1991, Group 1, Class B  
Immunity Standard: EN 55082 1:1992

MODEL NUMBERS	CONSTRUCTION	MAXIMUM FLOW RATE (at 20 psi diff. pressure, 70 °F)				Cv	CONNECTIONS
		AIR		WATER			
		sL/min	scfh	L/min	GPM		
<b>SMV20-A</b>	Aluminum	200	424	5.6	1.48	0.336	3/8"
<b>SMV20-S</b>	316 stainless steel/PTFE	200	424	5.6	1.48	0.336	3/8"
<b>SMV30-A</b>	Aluminum	500	1060	14.2	3.75	0.855	1/2"
<b>SMV30-S</b>	316 stainless steel/PTFE	500	1060	14.2	3.75	0.855	1/2"
<b>SMV40-A</b>	Aluminum	1000	2119	28	7.4	1.735	3/4" FNPT
<b>SMV40-S</b>	316 stainless steel/PTFE	1000	2119	28	7.4	1.735	3/4" FNPT

**TABLE I FLOW CONFIGURATIONS**

**4. OPERATING INSTRUCTIONS**

The SMV motorized valve requires a +12VDC power supply with a minimum current rating of 800 mA. The operating power and valve control signals are supplied via the 9-pin "D" connector located at the side of the valve.

The SMV motorized valve has three modes of operation: Valve Active (Auto), Valve OFF Control and Valve Purge (Open).

**4.1 Valve Active (Auto)**

For normal operating in Auto mode the motorized valve requires at least two control signals:

- Direction (12Vdc CMOS compatible logic level, pin 8 on the 9-pin "D" connector)
- Speed (0-2.5 VDC analog signal, pin 4 on the 9-pin "D" connector)

When direction is LOW (GND) valve goes down (closes), when direction is HIGH valve goes up (opens). The "speed" voltage on pin 4 determines how quickly the valve will operate. The signal amplitude for "speed" control signal must remain within the limits of 0 to +2.5 VDC. The 2.5 Vdc input signal corresponds to approximately 250 steps per second. With resolution of the stepping motor of 0.00025"/step it results in a maximum speed about 0.0625"/sec.

## **4.2 Valve OFF Control (Open Collector NPN Compatible)**

It may be necessary or desirable to set the flow and maintain that setting while being able to turn the flow control valve off and on again. Closing of the valve (without changing the "speed" and "direction" control signals) can be accomplished by connecting pin 3 of the 9-pin "D" connector to COMMON (power ground). The Motorized valve will be given the command to close indicated by a green light on top of the unit).

Conversely, when the connection is left open or pin 3 remains unconnected the valve remains active (executes "speed" and "direction" control signals). The valve will remain active when the VALVE OFF pin remains "floating".

This feature is compatible with open collector NPN transistor switches, as found in DC output ports of programmable controllers and similar devices.

The simplest means for utilizing the VALVE OFF control feature, is to connect a toggle switch between the COMMON and VALVE OFF pins of the SMV valve.

## **4.3 Valve Purge**

At times, it may be necessary to purge the flow system with a neutralizing gas such as pure dry nitrogen. The SMV valve is capable of a full open condition for the valve, regardless of setpoint conditions. Connecting the PURGE pin (pin 7 on 9 pin "D" connector) to ground will fully open the valve.

A red light on top of the valve will indicate an OPEN valve condition, normal for flow conditions.



Please note that the valve stays OPEN even if power is no longer applied. To CLOSE the Motorized Control Valve, connect pins 3 and 2.

## **5. TROUBLESHOOTING**

### **5.1 Common Conditions**

Your SMV motorized valve was thoroughly checked at numerous quality control points during and after manufacturing and assembly operations.

It was carefully packed to prevent damage during shipment. Should you feel that the instrument is not functioning properly please check for the following common conditions first:

Are all cables connected correctly?

Are there any leaks in the installation?

Is the power supply correctly selected according to requirements? When several meters are used a power supply with appropriate current rating should be selected.

Were the connector pinouts matched properly? When interchanging with other manufacturers' equipment, cables and connectors must be carefully wired for correct pin configurations.

## 5.2 Troubleshooting Guide

INDICATION	LIKELY REASON	REMEDY
no response to "speed" and "direction" control signals	inadequate gas pressure	apply appropriate gas pressure
	cable or connector malfunction	check cables and all connections or replace
	valve out of adjustment	return to factory for repair / replacement
valve does not work in OPEN position	incorrect valve adjustment	return to factory for repair / replacement
	pc board defect	return to factory for repair / replacement
	cable or connectors malfunction	check cable and connectors or replace
valve does not work in CLOSE position	incorrect valve adjustment	return to factory for repair / replacement
	pc board defect	return to factory for repair / replacement
	cable or connectors malfunction	check cable and connectors or replace

For best results it is recommended that instruments are returned to the factory for servicing. See section 1.3 for return procedures.

## 5.3 Technical Assistance

Aalborg® Instruments will provide technical assistance over the phone to qualified repair personnel. Please call our Technical Assistance at 800-866-3837. Please have your Serial Number and Model Number ready when you call.

# APPENDIX 1

## SMV MOTORIZED VALVE

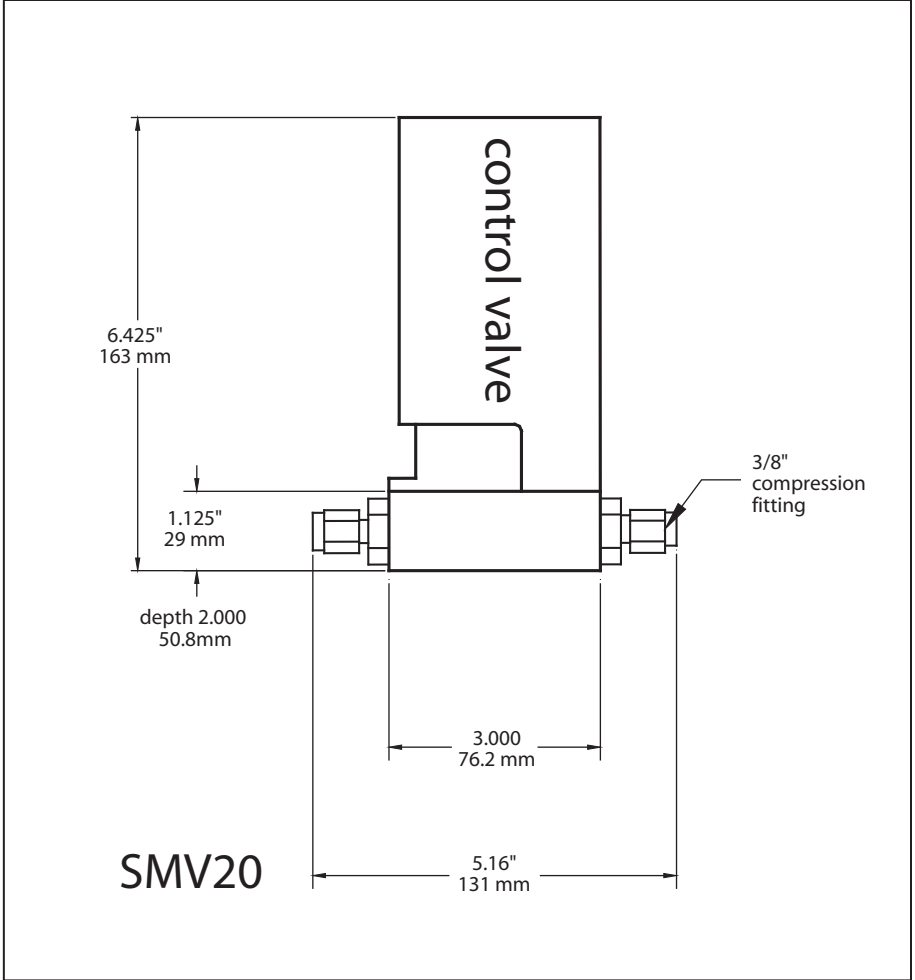

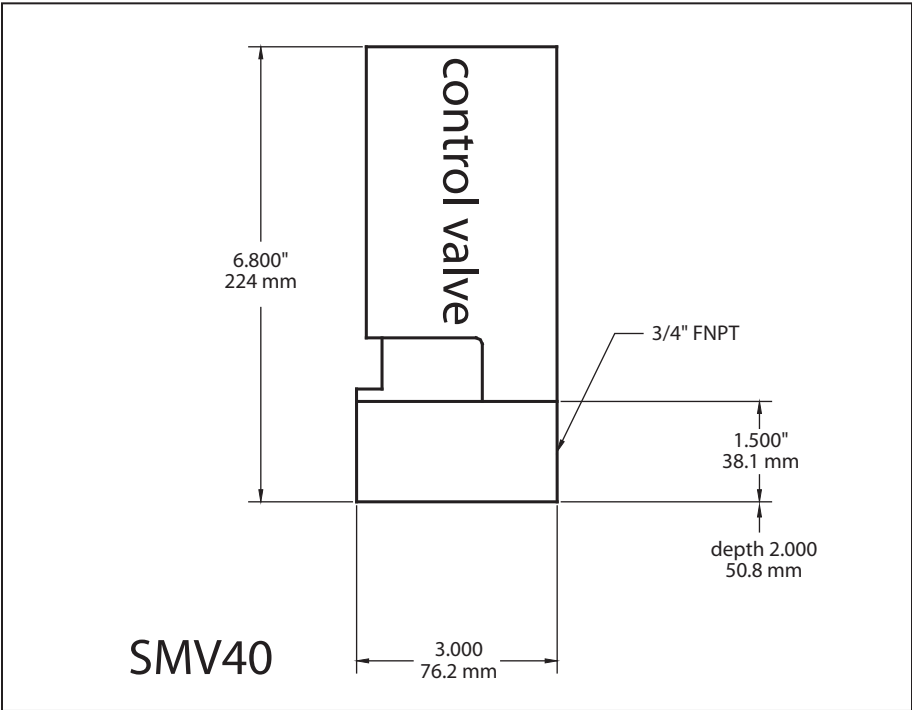
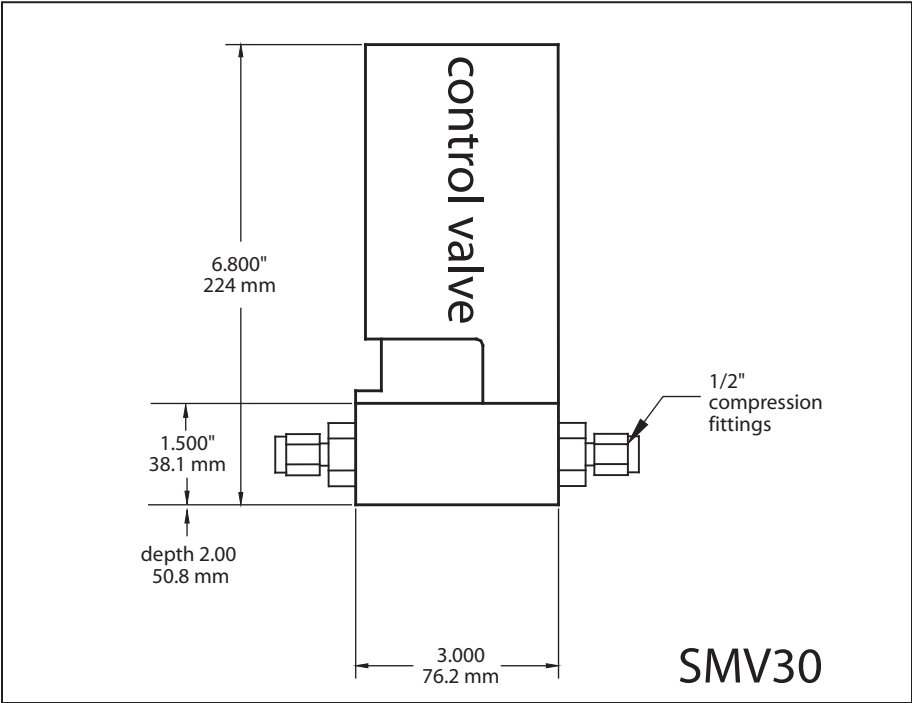

## APPENDIX 2

### WARRANTY

Aalborg® SMV motorized valves are warranted against parts and workmanship for a period of one year from the date of purchase. It is assumed that equipment selected by the customer is constructed of materials compatible with gases or liquids used. Proper selection is the responsibility of the customer. It is understood that gases under pressure present inherent hazards to the user and to equipment, and it is deemed the responsibility of the customer that only operators with basic knowledge of the equipment and its limitations are permitted to control and operate the equipment covered by this warranty. Anything to the contrary will automatically void the liability of Aalborg® and the provisions of this warranty. Defective products will be repaired or replaced solely at the discretion of Aalborg® at no charge. Shipping charges are to be borne by the customer. This warranty is void if the equipment is damaged by accident or misuse, or has been repaired or modified by anyone other than Aalborg® or factory authorized service facility. This warranty defines the obligation of Aalborg® and no other warranties expressed or implied are recognized.

NOTE: Follow Return Procedures In Section 1.3.

### CAUTION:

This product is not intended to be used in life support applications!