



PSV
Proportionating
Electromagnetic
Valve

**TABLE 73 -
MAX FLOW RATES AND CV VALUES FOR PSV**

MODEL NUMBER	ORIFICE SIZE		Cv	*MAXIMUM FLOW [mL/min]	
	[in]	[mm]		AIR	WATER
PSV1S-VA	0.02	0.51	0.009	3500	125
PSV2S-VA	0.04	1.02	0.033	13000	400
PSV3S-VA	0.055	1.4	0.055	21500	700
PSV4S-VA	0.063	1.6	0.068	25000	850
PSV5S-VA	0.125	3.18	0.24	100000	2850

*Based on 10 psig (690 mbar) differential pressure.

**The selection of materials of construction, is the responsibility of the customer. The company accepts no liability.

TABLE 74 - SPECIFICATIONS

POWER INPUT:	0-30Vdc.
MAXIMUM POWER REQUIRED:	400 mA.
TYPE OF OPERATION:	Normally closed (NC) when de-energized.
CONNECTIONS:	1/4" Compression fittings optional 1/8" and 3/8".
DIMENSIONS:	3.45" (87.6mm) high x 3.25" (82.6mm) long (including compression fittings) x 1.00" (25.4mm) deep.
**MATERIALS IN FLUID CONTACT:	Types 316 and 416 stainless steel, Viton® O-rings. Optional O-rings: Buna®, EPR and Kalrez®.
MAXIMUM PRESSURE:	1000 psig (6897 kPa).
MAXIMUM DIFFERENTIAL PRESSURE:	50 psid (345 kPa).
LEAK INTEGRITY:	1 X 10 ⁻⁹ smL/sec Helium individually tested.
MAXIMUM TEMPERATURE (typical):	174 °F (79 °C) inside, 130 °F (54 °C) outside surface at 24Vdc.

LIQUIDS AND GAS FLOW REGULATORS

PSV Proportionating Electromagnetic Valves are designed to respond to variable power inputs to proportionately regulate the flow of liquids and gases.

For added safety PSV valves are normally closed (NC) when de-energized. They can also serve as "ON-OFF" valves. For control functions see the PSV-D Driver Module.

Flow is controlled by increasing or decreasing the voltage applied to the coil. This causes a magnetic force which raises the core and allows gas to flow.

PSV valves, constructed of stainless steel are available in five different sizes covering flow ranges from 3.5 L/min - 100 L/min air and 125 mL/min - 2.85 L/min H₂O.

Design Features

- Leak Integrity 1 x 10⁻⁹ mL/min
- Rigid metallic construction
- Gas and liquids.
- Max pressure of 1000 psig (68.9 bars)

Principle of Operation

A variable stroke electromagnetic valve featuring a valve seat design which permits increasing or decreasing flow rates of liquids or gases through it in proportion to variable input power.

Regulator Systems

Complete flow regulating systems include a PSV electromagnetic valve connected to a pulse width modulated PSV-D Driver Module. For details see Driver Module description.

Pressure Drops Across PSV Valves

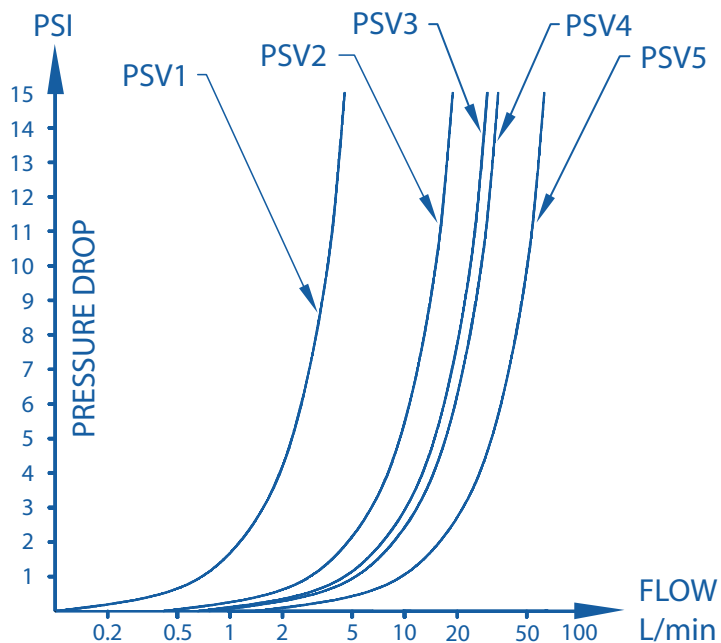

Cross Sectional View
PSV Valve

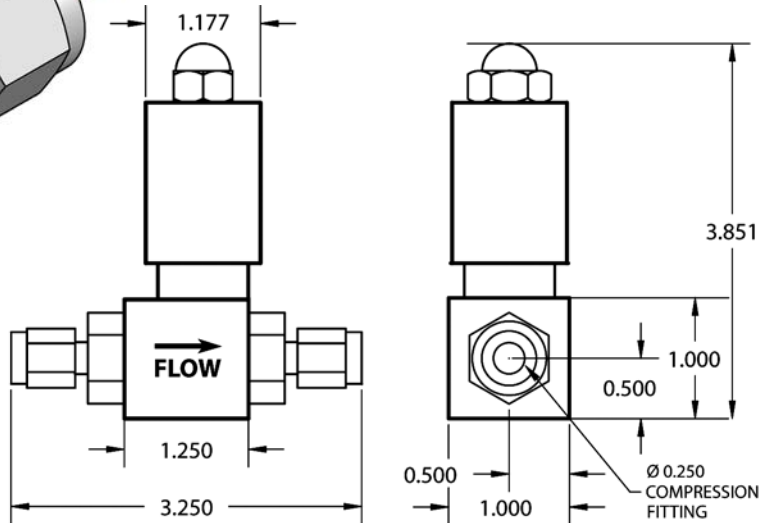
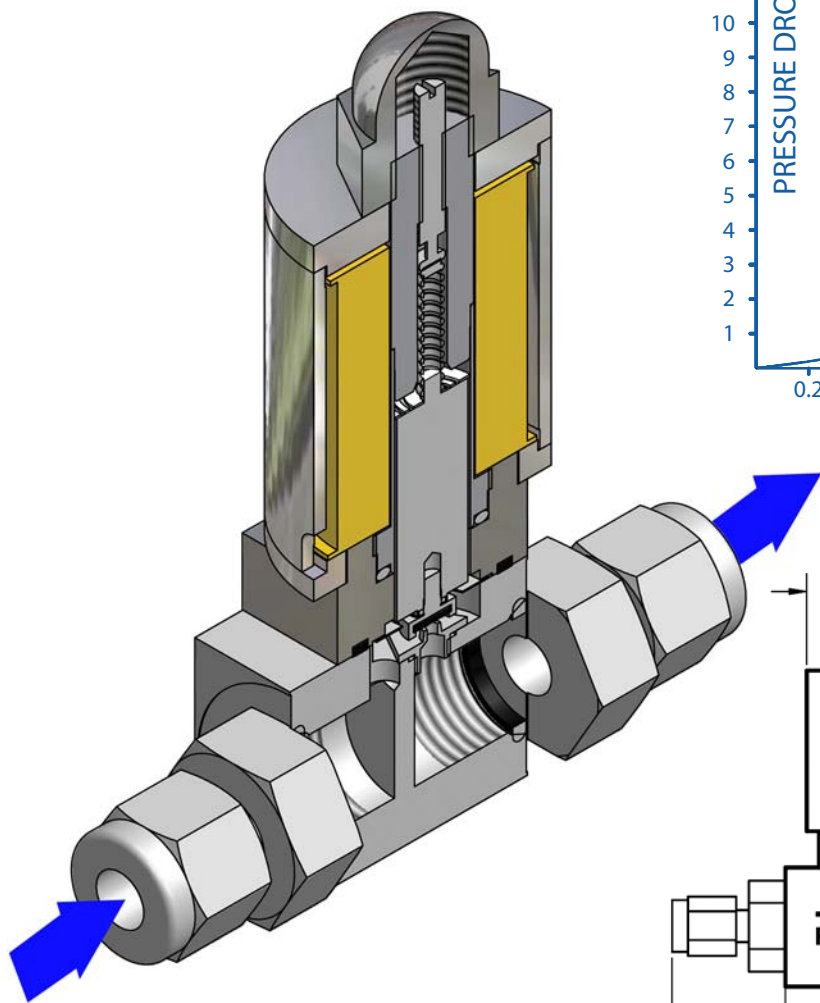

PSV Proportionating
Electromagnetic Valves

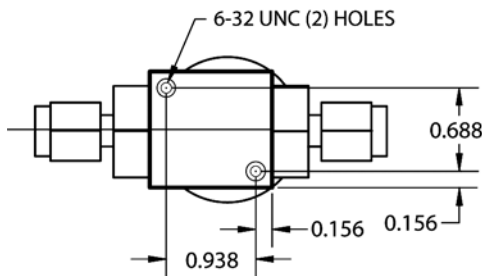

MODEL	
PSV	
SERIES	
1	
2	
3	
4	
5	
MATERIAL	
S	Stainless Steel
SEALS	
V	Viton®
B	Buna®
E	EPR
T	PTFE / Kalrez®
FITTINGS	
A	1/4" Compression
B	1/8" Compression
D	3/8" Compression
X	Special

PSV 4 S — V A

EXAMPLE: PSV4S-VA
 PSV4 stainless steel, Viton® seals with 1/4" compression fittings.

PSV-D

Pulse width modulated PSV-D Driver Modules regulate the power supplied to PSV Regulating valves based on a reference signal.

Set-point signals, 0-5 Vdc or 4-20 mA, input are employed to control the output pulse width modulated voltage at a fixed frequency ($\approx 30\text{KHz}$) and amplitude. Incoming power to the valve coil is applied and discontinued for predetermined periods of time by a low loss solid state switching element.

As incoming power is applied, energy in the inductive coils increases and when it is discontinued energy stored in the coil maintains the magnetic flux level required to hold flow at the controlled rate. This cycle takes place many thousands of times per second.

The wide range of power input features conveniently accommodates 12 to 32 Vdc sources.

The Auto-Select feature of the Driver Module recognizes the type of reference signal received and defaults to 0 - 5 Vdc if both signals are provided.



Shown with PSV Valve

Dimensions Pulse Width Modulated Driver Module

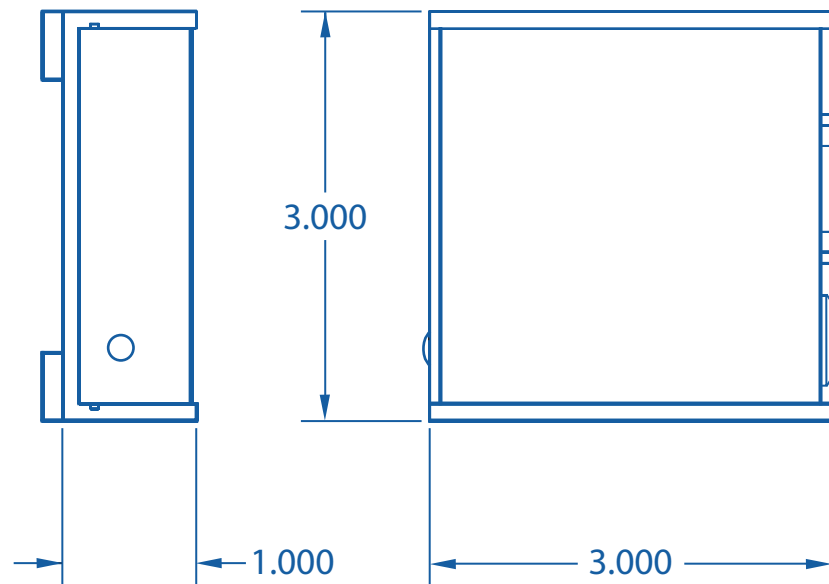

ORDERING INFORMATION PULSE WIDTH MODULATED DRIVER MODULES

PSV-D Output vs. Flow Ranges

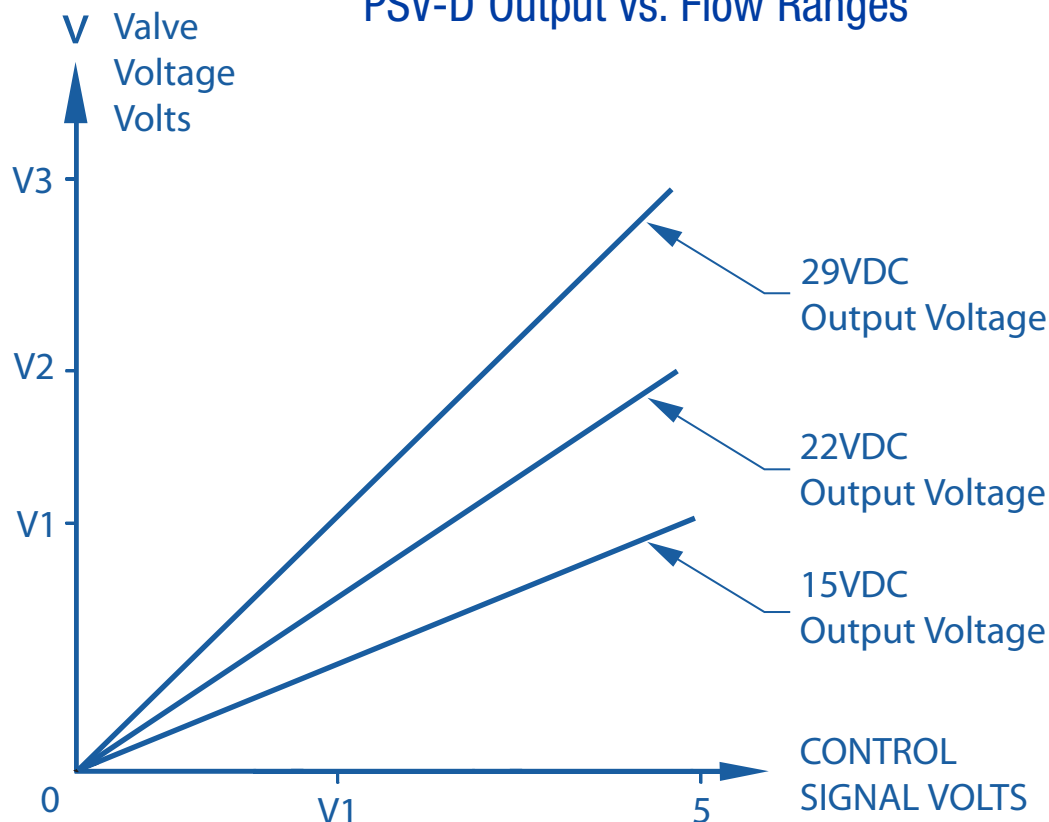

Jumper selectable output power allows a choice of dc voltage range for cooler more efficient operation, as a function of flow rates.

Internal resettable fuse protects electronics and rectifier circuits, prevents polarity reversal damage.

The maximum output voltage supplied to the PSV Valve can be set or changed in the field to allow for optimal use of the input reference signal to output voltage based on the specific flow rate and operating pressure applied to the valve.

TABLE 75 - SPECIFICATIONS

CONNECTION:	9-pin male "D" subconnector for input/output signals.
POWER INPUT REQUIRED:	+12 to 30 Vdc 1A @ 12 Vdc, 0.5A (not supplied) @ 24 Vdc via 9-pin "D"-connector or dc power jack (center positive).
INPUT SIGNAL:	Auto-Select feature allows circuit to recognize which analog input reference (0 to 5 Vdc or 4-20 mA) signal is provided.
TTL ON/OFF:	Jumper selectable LOW (0 Vdc) OFF-HIGH (5 Vdc) on, or reverse, to select valve ON/OFF status.
VALVE OUTPUT POWER:	Jumper selectable to +15, +22, and +29 Vdc with adjacent potentiometer to obtain ±2 Vdc.
FUSE RATING:	An internal resettable 1.6A fuse protects the electronics on the power input.
POLARITY PROTECTION:	Internal rectifier circuit protects from reversed polarity on the power input.
OPERATING TEMPERATURE:	32 °F (0 °C) to 122 °F (50 °C).
DIMENSIONS:	3" (7.62mm) wide x 3" (7.62mm) deep x 1" (25.4mm) high.
CE COMPLIANCE:	EMC Directive 89/336/EEC EN55011:1991 Group 1, Class A EN50082-2:1995.

ORDERING INFORMATION FOR PSV-D

MODEL	
PSV-D	Proportionating Solenoid Valve Driver
PSV-D	

TABLE 76 - ACCESSORIES FOR FOR PSVD DRIVER MODULE

PS-PSV-110NA-4	Power Supply, 110vac/24 Vdc /North America
PS-PSV-230EU-4	Power Supply, 230vac/24 Vdc /Europe
PS-PSV-240AU-4	Power Supply 240vac/24 Vdc /Australia
PS-PSV-240UK-4	Power Supply 240vac/24 Vdc /United Kingdom
CBL-DP9-6	Female 9 pin D-connector with 6 ft.cable